



**WHEEL LOADER | 411/417**

Engine power: 97–112kW Full turn tipping load: 5,451–6,042kg Shovel capacity: 1.4–1.6m<sup>3</sup>



# FULLY LOADED

The new JCB 411 and 417 Stage V wheel loaders are fully loaded with new and innovative features. These include a 4% more powerful and clean Stage V DIESELMAX engine with improved fuel efficiency and a new auto engine shutdown feature.



## FULLY PRODUCTIVE

Time is of the essence on any worksite and the 411 and 417 are designed to provide the fastest cycle times in the business.



## FULLY POWERED

Our cutting-edge, Stage V DIESELMAX engine takes power and efficiency to another level, combining efficient driveline and low fuel consumption.



## FULLY IN COMMAND

Our CommandPlus cab features the latest in ergonomic design, providing optimal control layout, comfort and visibility, enabling even greater operator productivity.



## FULLY PROTECTED

Superb visibility helps protect operators, bystanders and machine alike at all times. The 411 and 417 also have non-slip surfaces and excellent air filtration.

## FULLY SERVICEABLE

A one-piece bonnet with a large opening and easy ground level access to key components, both help to maximise your uptime.

STATIC DIMENSIONS

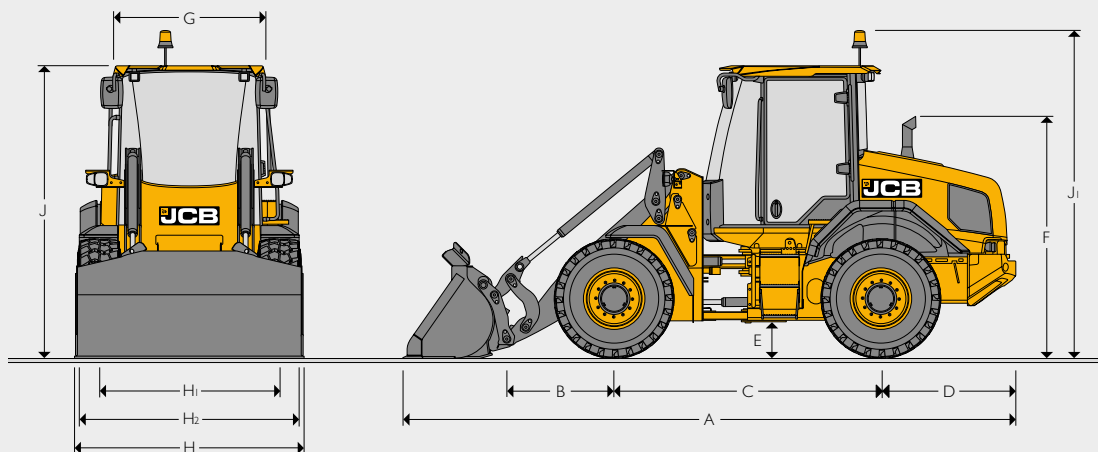

STATIC DIMENSIONS

		411 HT	417 HT	417 HT HL	417 HT SHL	
A	Overall length	mm	6229	6290	6491	7143
B	Axle to pivot pin	mm	1226	1110	1311	1963
C	Wheelbase	mm	2750	2800	2800	2800
D	Axle to counterweight face	mm	1365	1365	1365	1365
E	Minimum ground clearance	mm	344	371	371	371
F	Height over exhaust	mm	2575	2656	2656	2656
G	Width over cab	mm	1431	1431	1431	1431
H	Maximum width over tyres	mm	2204	2339	2339	2339
H1	Wheel track	mm	1800	1880	1880	1880
J	Height over cab	mm	3057	3084	3084	3084
J1	Height over raised beacon	mm	3403	3484	3484	3484
	Front axle weight	kg	3328	3790	3891	4437
	Rear axle weight	kg	5517	5977	5936	5737
	Total weight	kg	8845	9767	9827	10174

411 data based on machine equipped with direct mounted 1.2 m<sup>3</sup> bucket with toe plates and Michelin 15.5R25 XHA (L3) tyres.

417 data based on machine equipped with direct mounted 1.6 m<sup>3</sup> bucket with toe plates and Michelin 17.5R25 XHA2 (L3) tyres.

TURNING CIRCLE

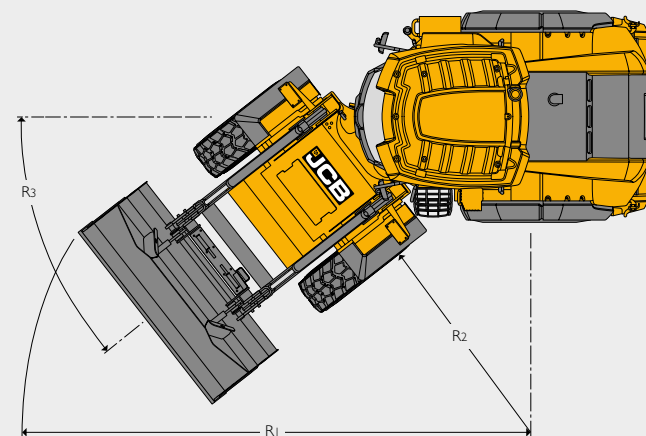

TURNING CIRCLE

			411 HT	417 HT	417 HT HL	417 HT SHL
R1	Max turn radius over shovel	mm	5351	5519	5519	5519
R2	Inside turn radius	mm	2658	2705	2705	2705
R3	Articulation angle	deg	+/-40	+/-40	+/-40	+/-40

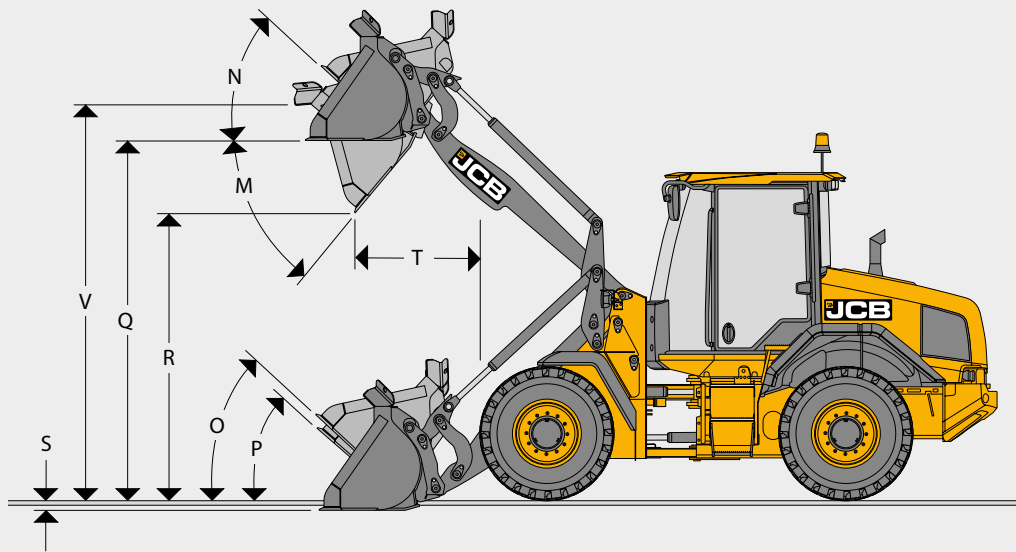

TYRE SIZE 411 HT					HT		Dimensions	
Tyre size	Manufacturer	Type	Rating	Operating weight (kg)	STL kg	F TTL kg	Vertical mm	Width mm
15.5-25	Goodyear	SGL D/L1 2 Ply	L2	-132	-88	-75	-9	-5
15.5-25	Goodyear	HRL D/L1 2 Ply	L3	-60	-40	-34	14	-5
15.5R25	Michelin	XTLA	L2	-44	-29	-25	-2	-7
15.5R25	Michelin	X-MINE D2	L5	640	426	362	54	14
17.5R25	Michelin	SNOPLUS	L2	276	184	156	25	84
17.5R25	Michelin	XTLA	L2	224	149	127	21	95
15.5R25	Nokian	LOADER GRIP 2	L3	-56	-37	-31	3	-10
17.5R25	Nokian	LOADER GRIP	L2	208	138	117	39	81

LOADER DIMENSIONS 411 HT

Model	411 HT										
	Direct						Quickhitch				
	Tipped teeth			Reversible toeplate			Tipped teeth		Reversible toeplate		
Shovel mounting											
Shovel type	General purpose						General purpose				
Shovel equipment	Tipped teeth			Reversible toeplate			Tipped teeth		Reversible toeplate		
Shovel capacity (SAE heaped 100%)	m <sup>3</sup>	1.2	1.4	1.2	1.4	1.6	1.2	1.4	1.2	1.4	1.6
Shovel capacity (struck)	m <sup>3</sup>	1.01	1.18	1.01	1.18	1.36	1.01	1.18	1.01	1.18	1.36
Shovel width	mm	2250	2400	2250	2400	2400	2250	2400	2250	2400	2400
Shovel weight	kg	528	603	528	603	638	505	580	505	580	614
Maximum material density*	kg/m <sup>3</sup>	2328	1947	2328	1947	1677	2224	1851	2224	1851	1591
Tipping load straight*	kg	6537	6392	6537	6392	6299	6276	6106	6276	6106	6005
Tipping load full turn*	kg	5585	5451	5585	5451	5366	5337	5182	5337	5182	5091
Payload*	kg	2793	2726	2793	2726	2683	2669	2591	2669	2591	2546
Maximum breakout force	kN	73.2	67.7	73.2	67.7	62.7	67.2	62.3	67.2	62.3	57.1
M Dump angle maximum	degrees	47	47	47	47	47	47	47	47	47	47
N Roll back angle full height	degrees	41	41	41	41	41	41	41	41	41	41
O Roll back at carry	degrees	46	46	46	46	46	46	46	46	46	46
P Roll back at ground level	degrees	42	42	42	42	42	42	42	42	42	42
Q Load over height	mm	3344	3346	3344	3346	3345	3363	3365	3363	3365	3366
R Dump height (45 deg dump)	mm	2780	2718	2780	2718	2668	2749	2687	2749	2687	2638
S Dig depth	mm	132	130	132	130	131	113	113	113	113	113
T Reach at dump height	mm	926	978	926	978	1030	980	1042	980	1042	1084
V Pin height (maximum)	mm	3569	3569	3569	3569	3569	3569	3569	3569	3569	3569
Reach maximum (45 deg dump) horizontal arm	mm	1661	1724	1661	1724	1774	1719	1782	1719	1782	1832
Operating weight (includes 80kg operator and full fuel tank (includes auxiliary tank))	kg	8655	8722	8655	8722	8756	8864	8931	8864	8931	8965

\*Assumes machine is fitted with Michelin 15.5R25 XHA tyres.

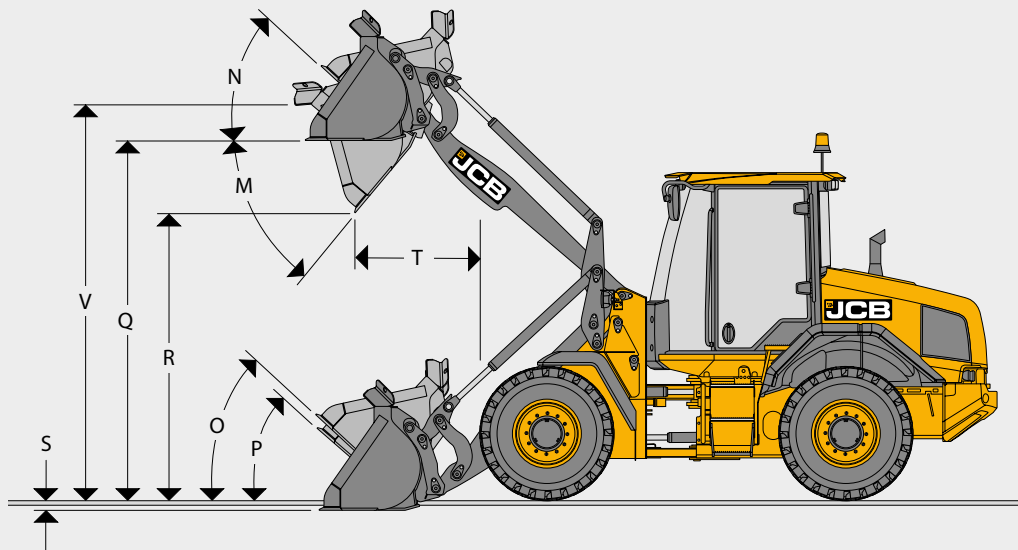

**TYRE SIZE 417 HT, HT HL, HT SHL**

Tyre size	Manufacturer	Type	Rating	Operating weight (kg)	HT		HT HL		HT SHL		Dimensions	
					STL kg	F TTL kg	STL kg	F TTL kg	STL kg	F TTL kg	Vertical mm	Width mm
17.5-25	Revolution	S2C2		1688	410	349	386	328	314	267	28	12
17.5-25	Revolution	SE		1688	410	349	386	328	314	267	28	12
17.5-25	Goodyear	SGL	L2	-184	-125	-106	-118	-100	-96	-82	2	9
17.5-25	Goodyear	HRL	L3	-52	-35	-30	-33	-28	-27	-23	15	2
17.5-25	Michelin	XTLA	L3	-92	-62	-53	-59	-50	-48	-41	-6	11
17.5-25	Michelin	XSNOPPLUS	L2	-40	-27	-23	-26	-22	-21	-18	-2	0
17.5-25	Michelin	X-MINE D2	L5	604	410	349	386	328	314	267	59	32
17.5-25	JCB	Earthmover	L3	104	70	60	66	57	54	46	31	-1
500/70R24	Michelin	XMCL		-196	-133	-113	-125	-106	-102	-87	1	163
17.5R25	Nokian	L GRIP	L2	-108	-73	-62	-69	-59	-56	-48	12	-3
17.5R25	BKT	XL GRIP	L3	-68	-46	-39	-43	-37	-35	-30	40	-3
600/55R26.5	Trelleborg	Twin Radial	Radial	140	95	81	90	77	73	62	23	388
20.5-25	Michelin	XHA	L3	504	342	291	324	277	262	223	62	180

**LOADER DIMENSIONS 417 HT, HT HL, HT SHL**

Model	417 HT								417 HT HL								417 HT SHL									
	Direct				Quickhitch				Direct				Quickhitch				Direct				Quickhitch					
	General purpose		Reversible toeplate		General purpose		Reversible toeplate		General purpose		Reversible toeplate		General purpose		Reversible toeplate		General purpose		Reversible toeplate		General purpose		Reversible toeplate			
Shovel mounting	Tipped teeth		Reversible toeplate		Tipped teeth		Reversible toeplate		Tipped teeth		Reversible toeplate		Tipped teeth		Reversible toeplate		Tipped teeth		Reversible toeplate		Tipped teeth		Reversible toeplate			
Shovel type	2400		2400		2400		2400		2400		2400		2400		2400		2400		2400		2400		2400			
Shovel equipment	658		698		680		720		643		683		665		705		658		698		680		720			
Shovel capacity (SAE heaped 100%)	1.4	1.6	1.4	1.6	1.4	1.6	1.4	1.6	1.4	1.6	1.4	1.6	1.4	1.6	1.4	1.6	1.4	1.6	1.4	1.6	1.4	1.6	1.4	1.6		
Shovel capacity (struck)	1.18	1.36	1.18	1.36	1.18	1.36	1.18	1.36	1.18	1.36	1.18	1.36	1.18	1.36	1.18	1.36	1.18	1.36	1.18	1.36	1.18	1.36	1.18	1.36		
Shovel width	2400		2400		2400		2400		2400		2400		2400		2400		2400		2400		2400		2400		2400	
Shovel weight	658		698		680		720		643		683		665		705		658		698		680		720		705	
Maximum material density *	2189	1888	2189	1888	2088	1802	2088	1802	2039	1760	2039	1760	1945	1668	1945	1668	1499	1294	1499	1294	1419	1224	1419	1224		
Tipping load straight *	7236	7141	7236	7141	6932	6844	6932	6844	6748	6666	6748	6666	6469	6392	6469	6392	5038	4976	5038	4976	4803	4745	4803	4745		
Tipping load full turn *	6129	6042	6129	6042	5847	5767	5847	5767	5707	5632	5707	5632	5445	5337	5445	5337	4196	4139	4196	4139	3972	3918	3972	3918		
Payload *	3065	3021	3065	3021	2924	2884	2924	2884	2854	2816	2854	2816	2723	2669	2723	2669	2098	2070	2098	2070	1986	1959	1986	1959		
Maximum breakout force	70	64.6	70	64.6	64.9	59.9	64.9	59.9	70	64.6	70	64.6	64.9	59.9	64.9	59.9	70	64.6	70	64.6	64.9	59.9	64.9	59.9		
M Dump angle maximum	50	50	50	50	51	50	51	50	47	47	47	47	47	46	47	46	45	45	45	45	45	45	45	45		
N Roll back angle full height	43	43	43	43	43	43	43	43	43	43	43	43	43	43	43	43	47	47	47	47	47	47	47	47		
O Roll back at carry	44	44	44	44	43	43	43	43	43	43	43	43	43	43	43	43	45	45	45	45	45	45	45	47		
P Roll back at ground level	41	41	41	41	41	41	41	41	42	42	42	42	42	42	42	42	44	43	44	43	43	45	43	45		
Q Load over height	3341	3343	3341	3343	3339	3358	3339	3358	3559	3554	3559	3554	3568	3567	3568	3567	4202	4199	4202	4199	4216	4216	4216	4216		
R Dump height (45 deg dump)	2714	2666	2714	2666	2661	2631	2661	2631	2930	2878	2930	2878	2890	2839	2890	2839	3575	3522	3575	3522	3538	3488	3538	3488		
S Dig depth	110	109	110	109	92	92	92	92	116	111	116	111	96	96	96	96	148	152	148	152	132	132	132	132		
T Reach at dump height	930	973	930	973	993	1031	993	1031	986	1034	986	1034	1046	1097	1046	1097	1074	1122	1074	1122	1130	1180	1130	1180		
V Pin height (maximum)	3566	3566	3566	3566	3566	3566	3566	3566	3946	3946	3946	3946	3946	3946	3946	3946	4411	4411	4411	4411	4411	4411	4411	4411		
Reach maximum (45 deg dump) horizontal arm	1639	1688	1639	1688	1697	1746	1697	1746	1790	1839	1790	1839	1848	1897	1848	1897	2319	2369	2319	2369	2377	2427	2377	2427		
Operating weight (includes 80kg operator and full fuel tank (includes auxiliary tank))	9567	9602	9567	9602	9777	9812	9777	9812	9617	9652	9617	9652	9827	9862	9827	9862	9907	9942	9907	9942	10117	10452	10117	10152		

\* Assumes machine is fitted with Michelin 17.5 R25 XHA tyres.

LOADER DIMENSIONS – FORK FRAME WITH FORKS

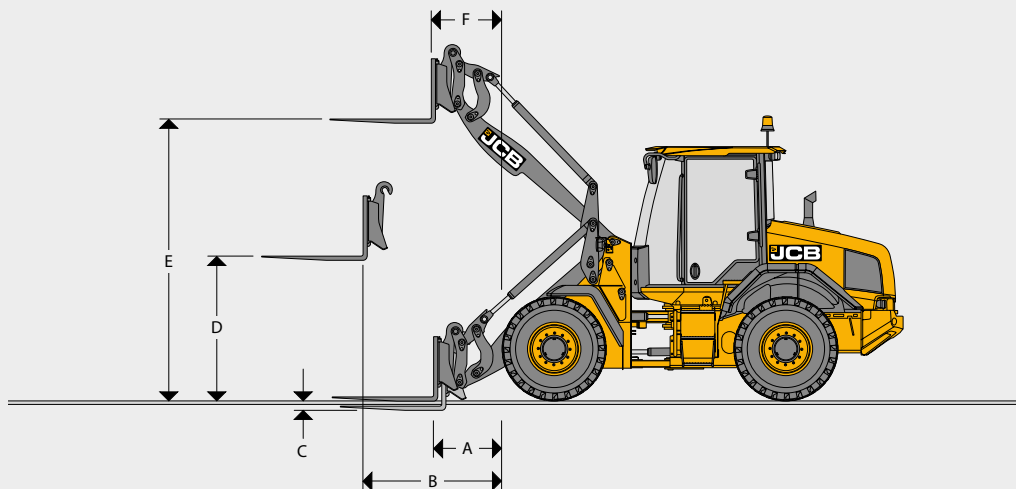

LOADER DIMENSIONS – FORK FRAME WITH FORKS

		Parallel fork				Non parallel fork			
		411 HT	417 HT	417 HT HL	417 HT SHL	411 HT	417 HT	417 HT HL	417 HT SHL
Fork carriage width	mm	1500	1500	1500	1500	1500	1500	1500	1500
Length of tines	mm	1220	1220	1220	1220	1220	1220	1220	1220
A Reach at ground level	mm	924	787	969	1620	923	785	984	1631
B Reach at arms horizontal	mm	1527	1459	1590	2115	1512	1447	1596	2118
C Below ground level	mm	78	57	55	79	62	68	64	88
D Arms, horizontal height	mm	1671	1745	1744	1744	1626	1735	1735	1735
E Arms, maximum height	mm	3395	3395	3618	4267	3414	3385	3599	4257
F Reach at maximum height	mm	823	829	806	846	776	817	819	853
Payload*	kg	3360	3722	3482	2630	3477	3714	3466	2622
Tipping load straight	kg	4948	5480	5172	3977	5093	5505	5150	3965
Tipping load full turn (40°)	kg	4200	4653	4353	3288	4346	4642	4333	3278
Attachment weight	kg	435	435	435	435	430	430	430	430

Assumes the fitment of Michelin 15.5R25 XHLA (L3) tyres for 411 and Michelin 17.5R25 XHA (L3) tyres for 417.

Manual fork spacing's at 50mm increments. Fork section 100mm x 50mm.

\* At the centre of gravity distance 500mm. Based on 80% of FTTL as defined in ISO 8313.

BUCKET SELECTOR

Material	Loose density (kg/m³)	Fill factor (%)
Snow (fresh)	200	110
Peat (dry)	400	100
Sugar beet	530	100
Coke (loose)	570	85
Barley	600	85
Petroleum coke	680	85
Wheat	730	85
Coal bituminous	765	100
Fertiliser (mixed)	1030	85
Coal anthracite	1046	100
Earth (dry) (loose)	1150	100
Nitrate fertiliser	1250	85
Sodium chloride (dry) (salt)	1300	85
Cement Portland	1440	100
Limestone (crushed)	1530	100
Sand (dry)	1550	100
Asphalt	1600	100
Gravel (dry)	1650	85
Clay (wet)	1680	110
Sand (wet)	1890	110
Fire clay	2080	100
Copper (concentrate)	2300	85
Slate	2800	100
Magnetite	3204	100

411 - HT

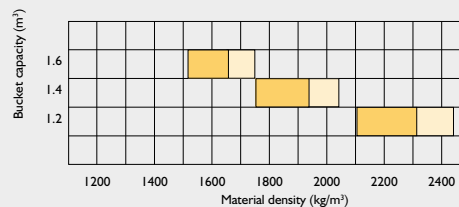

417 - HT

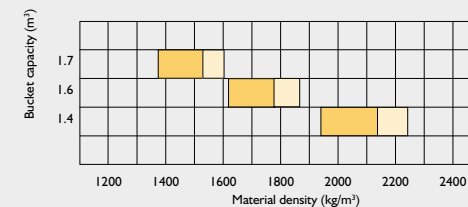

417 - HT HL

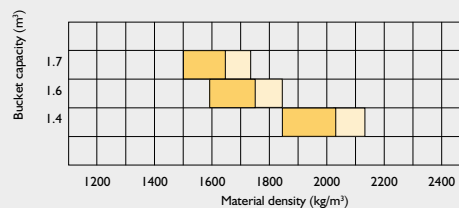

417 - HT SHL

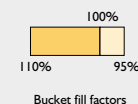
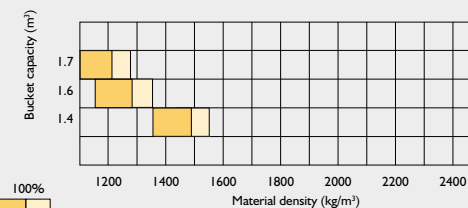

ENGINE			
		411	417
Manufacturer			
Model		JCB DIESELMAX	JCB DIESELMAX
Capacity	litres	4.8	4.8
Cylinders		4	4
Bore	mm	106	106
Stroke	mm	139	139
Aspiration		Turbo charged	Turbo charged
Max Power	kW (hp) @ 2200 rpm	81 (109)	97 (130)
Rated Power	kW (hp) @ 2200 rpm	81 (109)	97 (130)
Power @ Max Torque	kW (hp) @ 1500 rpm	78.4 (105)	88 (118)
Max Torque	Nm	516@1450	550@1500
Valves per cylinder		4	4
Air cleaner		Cyclonic Pre filter	Cyclonic Pre filter
Fan drive type		Standard: Viscous Drive Fan Option: Hydraulic (Auto Reverse)	Standard: Viscous Drive Fan Option: Hydraulic (Auto Reverse)
Emissions		Stage V	Stage V

TRANSMISSION					
		411		417	
		Smooth shift Powershift			
Type / Model		ZF 4WG115			
Torque convertor stall ration		3.01:1		2.3:1	
		Forward	Reverse	Forward	Reverse
<b>40kph</b>					
1 <sup>st</sup> gear	kph	5.5	5.8	5.4	5.7
2 <sup>nd</sup> gear	kph	13	13.7	12.8	13.5
3 <sup>rd</sup> gear	kph	28.8	30.1	28.4	29.8
4 <sup>th</sup> gear	kph	40	-	40	-

LOADER HYDRAULICS			
		411	417
Pump type		Double gear pump	Variable placement piston pump
Pump 1 maximum flow	l/min	50.6	156
Pump 1 maximum pressure	bar	220	240
Pump 2 maximum flow	l/min	72.6	-
Pump 2 maximum pressure	bar	230	-
<b>Hydraulic cycle times at full engine revs</b>		<b>411</b>	<b>417</b>
Arms raise (full bucket)	Seconds	5.0	4.9
Bucket dump (full bucket)	Seconds	1.1	2.1
Arms lower (empty bucket)	Seconds	3.7	3.3
Total cycle	Seconds	9.8	10.3

AXLES			
411			
Type		Epicyclic hub reduction	
Make & model	Standard fit	JCB PD70 (front & rear)	
Overall axle ratio 40kph		18.16:1	
Rear axle oscillation		± 11°	
417			
Type		Epicyclic hub reduction	
Make & model	Standard fit	JCB PD87 (front & rear)	
Overall axle ratio 40kph		20.18:1	
Rear axle oscillation		± 11°	
<b>STEERING</b>	Hydraulic power steering system with emergency steering.		
<b>BRAKES</b>	Hydraulic power braking on all wheels. In board mounted, oil immersed, multi-plate disc brakes. Mechanically or Electro-Hydraulically activated disc type parking brake operating on transmission output shaft.		
<b>CAB</b>	In-cab noise level – 68dB(A). External Noise 103dB(A).		

ELECTRICAL SYSTEM			
		411	417
System voltage	Volt	24	
Alternator output	Amp hour	100	
Battery capacity	Amp hour	2 x 110	

SERVICE FILL CAPACITIES			
		411	417
Hydraulic system	litres	155	
Fuel tank	litres	116	
Auxiliary fuel tank	litres	111	
DEF	litres	20	

NOISE AND VIBRATION					
				Uncertainty	Measurement conditions.
Noise at the operator station	LpA	68 dB	+/- 1 dB		Determined in accordance with the test method defined in ISO 6396 and the dynamic test condition defined on 2000/14/EC.
Noise emission from the machine	LWA	103 dB	+/- 1 dB		Guaranteed equivalent sound power (external noise) determined in accordance with the dynamic test conditions defined in 2000/14/EC.
Whole body vibration	m/s <sup>2</sup>	0.58	+/- 0.11 dB		ISO 2632-1:1997 normalised to an 8h reference period and based upon a test cycle comprising of loader work (soil).
Hand-arm vibration	m/s <sup>2</sup>	<2.5	N/A		ISO 5349-2:2001 dynamic test conditions.

## EQUIPMENT

## SERVICE AND MAINTENANCE

5 year LiveLink telematics	•
Engine oil remote drain and fill	•
Grouped pressure test points	•
Lockable tool box	•
Lubrication points accessible from ground level	•
Transmission oil level sight gauge	•
Hydraulic level sight gauge	•

## ENGINE

Air cleaner – cyclonic pre-filter with engine fan scavenge system	•
Fixed viscous mounted fan	•
Automatically reversing cooling fan	+
Crankcase breather oil trap	•
DEF fluid	•
Epoxy coated radiator / coolers	+
Fuel filter	•
Fuel pre-filter with water trap	•
Hydraulically driven cooling fan	•
-20° cold start	•
DPF / SCR engine emission control	•
Waste gated turbo	•
Widcore radiator	•
Auto engine idle shut down timer (in cab adjustable)	•

## ELECTRICAL

100 amp alternator	•
Amber rotating beacon	•
Green seatbelt beacon	+
Electrical adjustable mirrors	•
Heated mirrors	•
External battery isolator	•
Fold down beacon arm	•
Halogen front and rear working lights	•
Full road light kit	•
Integrated rear view camera	•
LED front and rear working lights	+
LED 360° work lights	+
Number plate light kit	+
Radio wiring and speakers	•
Reverse alarm	•
Smart reverse alarm	+
White noise reverse alarm and light	+

## DRIVE TRAIN

4 speed transmission 40kph	•
Gear kick down on loader control lever	•
Loader lever direction control	•
Neutral start	•
Open differential	•
Limited slip differentials front and rear	+
Oscillating rear axle	•
Foot brake operated transmission disconnect (selectable)	•
Selectable automatic powershift	•
Speed limiter 20kph	+
Steering column single lever shift control (direction and gear)	•
Transmission cooler bypass	+

## BRAKE SYSTEM

Multi-plate wet disc brakes	•
Parking disc brake on transmission output shaft	•
Mechanical hand operated park brake	•
Electrical hydraulic park brake	+
Independent accumulator backup for electric park brake	+

## OPERATOR STATION

Fully glazed cab	•
Front windscreen guards	+
Air conditioning	•
Climate control	+
Single lever joystick	•
Multi-lever hydraulic controls	+
Proportional electro-hydraulic auxiliary control	+
Electronic adjustment of SRS (Smooth Ride System) cut-in speed	+
Electronic adjustment of reverse fan interval	+
Air suspension cloth seat	•
Deluxe heated air suspension cloth seat	+
Super deluxe heated & cooled air suspension half leather seat	+
Front roller blind	•
Rear roller blind	+
Cab air intake filter	•
Carbon cab air intake filter	+
12V in cab power socket	•
2 x 12V in cab power socket	+
24V in cab power socket	+
Reversing camera (colour)	•
Fold away adjustable steering column	•
ROPS / FOPS safety structure	•
Interior light	•

## OPERATOR STATION (CONTINUED)

Front primary display screen	•
Secondary A post display screen, rotary control menu interface	+
A post mounted membrane switches	•
50 mm seatbelt	•
75 mm seatbelt	+
Fire extinguisher (UK & USA only)	+
Two speed intermittent front windscreen wipe / wash and self-park	•
Single speed rear windscreen wipe/wash and self-park	•
3 speed heater/demisting	•
LH and RH sliding opening windows	•
Floor mat	•
Cup holder	•
Steering wheel spinner knob	•
Internal rear view mirror	•
Tinted cab glass	•
Multimedia port (USB and 3.5mm)	+
Operator stowage	•
Laminated windscreen	•
Heated rear screen	•
Loader control isolator	•
Horn	•
Adjustable armrest	•
Removable storage rubber mats	•

## FRONT PRIMARY DISPLAY

## Warning lights

Direction indicators	•
Master warning	•
High coolant temperature	•
Battery charging condition	•
Low fuel level	•
Engine oil pressure	•
Hazard lamps	•
Park roller blind	•
Road lights	•
Main beam lights	•
Rear fog lights	•
Engine pre-heat	•
Brake system pressure	•
Low steering pressure	•

## Buzzer alerts

Engine air filter blocked	•
Diesel exhaust fluid (DEF)	•
Torque reduction in case of malfunction	•
Amber warning lamp	•



## EQUIPMENT

## FRONT PRIMARY DISPLAY (CONTINUED)

Gauge display	
Engine speed	•
Coolant temperature	•
Fuel level	•
LCD screen display	
Current gear	•
Torque reduction in case of malfunction	•
Amber warning lamp	•
Diesel exhaust fluid (DEF)	•
Secondary steer system pressure	•
Steer mode	•
Ground speed	•
Engine Speed (numeric display)	•
Clock	•
Hydraulic state	•
SRS (Smooth Ride System)	+
Beacon	•
Front work lamps	•
Rear work lamps	•
Heated rear screen	•
Transmission sump temperature	•
Data screens	
DEF level	•
Hydraulic oil temperature	•
Torque convertor temperature	•
Volume of fuel remaining	•
Total fuel used (resettable)	•
Instantaneous fuel use	•
Average fuel use (resettable)	•
Current date	•
Machine hours	•
Trip distance (resettable)	•
Hours to service	•
Daily checks	•
Engine oil level	•
DEF level	•
RIGHT HAND SECONDARY DISPLAY - OPTIONAL	
Clock	•
Climate control	•
Fan speed	•
In-cab temperature set	•
Machine hours	•
Rear view camera	•
Fuel use	•

## RIGHT HAND SECONDARY DISPLAY - OPTIONAL (CONTINUED)

Time and date	•
Auxiliary flow rate	+
Hydraulic oil temperature	•
Transmission oil temperature	•
Machine settings screen	
Coolant temperature	•
Engine oil pressure	•
Air filter	•
Transmission sump temperature	•
Transmission torque convertor temperature	•
Hydraulic oil temperature	•
Battery voltage	•
Help display	•
On-screen handbook	•
HYDRAULIC SYSTEM	
Smoothride system (SRS)	+
Hydraulic quickhitch with in-cab isolation	+
Auxiliary ARV kit	+
Auxiliary hydraulic service	+
Twin auxiliary hydraulic service	+
Emergency steer back-up	•
JCB biodegradable hydraulic oil	+
Electronic hydraulic isolation	•
Automatic boom kick-out. Detent	•
Automatic bucket positioner	•
Front loader float	•
Hydraulic oil cooler	•
EXTERNAL EQUIPMENT	
Front and rear fenders	•
Front adjustable mud flaps	•
Front wheel spray guards	•
Automatic greasing system	+
Grease gun and cartridge	+
Mesh air intake screens	•
Flexible bottom step	•
Full width rear counterweight	•
Chevron rear counterweight	+
Recovery hitch	•
Lifting / tie down lugs	•
Auxiliary fuel tank	+

## PROTECTIVE EQUIPMENT

Front cab screen guards	+
Wastemaster package: includes front and rear light guards, front screen guard, Wastemaster decal.	+
Rear grille guard	+
Loader arm safety strut	•
Light guards	+
Belly guard kit	•
Articulation joint safety strut	•

## OTHER EQUIPMENT

High lift loader end (417 only)	+
Super high lift loader end (417 only)	+

STANDARD •

OPTIONAL +







**ONE COMPANY, OVER 300 MACHINES.**

Your nearest JCB dealer

**Wheel Loader 411/417**

Engine power: 97–112kW Full turn tipping load: 5,451–6,042kg Shovel capacity: 1.4–1.6m<sup>3</sup>

JCB Sales Limited, Rokeceter, Staffordshire, United Kingdom ST14 5JP.

Tel: +44 (0)1889 590312 Email: [salesinfo@jcb.com](mailto:salesinfo@jcb.com)

Download the very latest information on this product range at: [www.jcb.com](http://www.jcb.com)

©2022 JCB Sales. All rights reserved. No part of this publication may be reproduced, stored in a retrieval system, or transmitted in any form or by any other means, electronic, mechanical, photocopying or otherwise, without prior permission from JCB Sales. All references in this publication to operating weights, sizes, capacities and other performance measurements are provided for guidance only and may vary dependant upon the exact specification of machine. They should not therefore be relied upon in relation to suitability for a particular application. Guidance and advice should always be sought from your JCB Dealer. JCB reserves the right to change specifications without notice. Illustrations and specifications shown may include optional equipment and accessories. The JCB logo is a registered trademark of J C Bamford Excavators Ltd.

